



Hale Trailer Brake & Wheel

A001770-A001775



MAG FA5160 54 (Model: AXM516054RS)

Detailed Specifications		General
SKU	AXM516054RS	
Length	4 feet 6 inches	
Width	8 feet 6 inches	
Compatibility	MAG 51, MAG 55H, MAG 55M, MAG 55MX, MAG 55L P, MAG 60	
Weight	Est. Configured Weight: 2810# +/- 3%	
Rear Bridge: General		
Boom Trough	V Crossmembers with Bolt-In V Pan	
Rear Bridge: Axles		
Number of Axles	1	
Axle Capacity	25,000 lb. Nominal Capacity Per Axle NOTE: GAWR Determined by Suspension Type, Brakes, Tires and Other Components.	
Brakes	16.5 inches x 7 inches with 5.5 inches Autoslacks - Heavy Duty Brake Drums - Outboard Mount	
Dust Shield	None	
Hubodometer	None	
Rear Bridge: Suspension		
Manual Dump Valve	Manual Dump Valve	
Load Scale	None	
Wheels and Tires		
Wheels	8.25 x 22.5 Steel Disc - Hub-Piloted	
Tires	275/70R 22.5 H Ply OEM Standard	
Inflation	None	
Lighting		
Electrical System	DOT Sealed Beam and Harness with LED Lights and 4-inch Flush Mounted Battery Powered Amber Strobes	
Tail Lights	3 Tail Light Package	
Bumper	Heavy Duty V-Style Rear Bumper	
Paint		
Paint	Fontaine Black Polyurethane Enamel	
Miscellaneous		
Lash Rings	1 Pair - 2 Total	
Flag Holders	1 Pair Flag Holders	
Terms		
Please Note	Price Includes Commodity Surcharges	
Commercial Terms	Ex Works- Springville, AL, USA	

DISCLAIMER

Specifications are believed to be correct, but may contain errors and/or omissions. Photographs are the representative of the subject equipment but may not be identical. Equipment availability, prices and specifications are subject to change without notice.

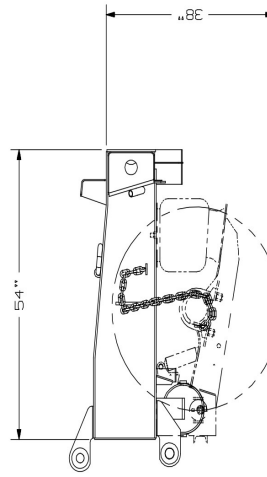
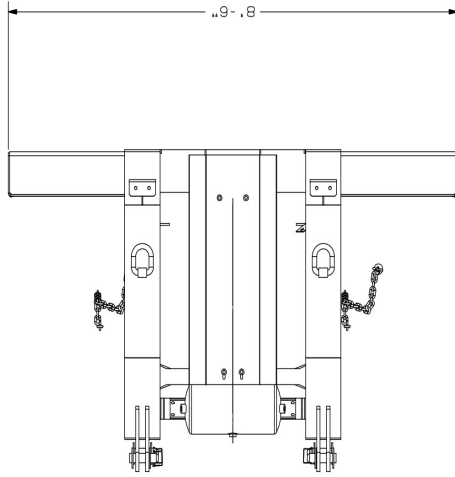

FONTAINE HEAVY-HAUL
SPRINGVILLE, AL

THIS DRAWING AND THE INFORMATION CONTAINED HEREIN ARE THE PROPERTY OF FONTAINE HEAVY-HAUL. ALL RIGHTS ARE RESERVED. NO PART OF THIS DRAWING OR THE INFORMATION CONTAINED HEREIN MAY BE REPRODUCED OR TRANSMITTED IN ANY FORM OR BY ANY MEANS, ELECTRONIC OR MECHANICAL, INCLUDING PHOTOCOPYING, RECORDING, OR BY ANY INFORMATION STORAGE AND RETRIEVAL SYSTEM, WITHOUT PERMISSION IN WRITING BY FONTAINE HEAVY-HAUL.