

# Hale Trailer Brake & Wheel

A006470-A006493

VIN: 079354-079377



## ALUMINUM "BST II" PLATFORM TRAILER



|  |  |                      |   |
|--|--|----------------------|---|
| <b>LENGTH:</b>   | 48' - 24" BEAM   | <b>SUSPENSION:</b>   | AAT25K/E2-1 W/ 'K' BRACING  |
| <b>WIDTH:</b>  | 102"   |                      | GALVANIZED HANGERS & SOFTCOAT PAINT   |
| <b>NOSE:</b>   | SQUARE + EXTRA ISO 7 WAY PLUG (1)(3)                                   | <b>LOWERING KIT:</b> | AUTOMATIC   |
| <b>KING PIN SETTING:</b>   | 30" W/ 5/16" STEEL-NO ACCESS HOLES                                     | <b>AXLE TO AXLE:</b> | 121"  |
| <b>FLOOR:</b>  | KNURLED ALUMINUM<br>3 NAILERS<br>INTEGRATED SIDE RAIL                  | <b>AXLE TO REAR:</b> | 30"   |
| <b>XMEMBER SPACING:</b>  | 16"  | <b>LIFT / AXLE:</b>  | N/A   |
| <b>COIL PACKAGE:</b>   | YES (CENTER)- 8 PCS BAR INSERTS  | <b>SPACING:</b>      | N/A   |
| <b>SPOOLS:</b>   | DOUBLE   | <b>F.W. HEIGHT:</b>  | 49"   |
| <b>POCKETS:</b>  | HD FRONT TO ACCEPT AERO BH-SEE DWG                                     | <b>CONTROLS:</b>     | N/A   |
| <b>ROPE HOOKS:</b>   | NONE   | <b>AXLES:</b>        | TP<br>23,000 GAWR   |
| <b>TIE DOWNS:</b>  | 10 PR J-HOOKS & 2 STORAGE PIPES @ D/S LG                               | <b>AUTO SLACKS:</b>  | MERITOR   |
| <b>MARKER LIGHTS:</b>  | LED - 6 PR EACH SIDE ON RAIL   | <b>BRAKES:</b>       | 16 1/2" X 7"  |
| <b>MID TURN SIGNAL:</b>  | LED- COMBO MARKER / MMTS BELOW RAIL                                    | <b>ABS SYSTEM:</b>   | 4S/2M (SENSOR ALL)  |
| <b>FLAT</b> <input checked="" type="radio"/> <b>ANGLED</b> <input type="radio"/> |  | <b>HUBS:</b>         | 10 STUD LW STEEL  |
| <b>LIGHT PANEL:</b>  | LED - 9 LIGHTS (OOO ooo OOO)<br>1/2 STEPS ON REAR<br>FULL WIDTH BUMPER | <b>DRUMS:</b>        | LWBD  |
| <b>BULKHEAD:</b>   | NONE   | <b>WHEELS:</b>       | 8.25 X 22.5 4HP / 4 MP  |
| <b>TYPE:</b>   |  | <b>TIRES:</b>        | 11R 22.5 R196A 14 PLY BRIDGESTONE   |
| <b>HEIGHT:</b>   |  | <b>LANDING GEAR:</b> | JOST AX150 ALUMILIGHT D/S CRANK<br>FORWARD BRACING (2)  |
| <b>RETURNS:</b>  |  | <b>TIRE CARRIER:</b> | BRACKETS ONLY - P/S ACCESS MID TRAILER  |
| <b>MAT'L:</b>  |  | <b>TOOLBOX:</b>      | <b>QTY:</b> ONE-AERO EXTREME 1/8"<br><b>SIZE:</b> 24" X 24" X 60"<br><b>LOCATION:</b> D/S-BETWEEN AXLES<br><b>MAT'L:</b> AERO DOUBLE DOOR-SMOOTH ALUM<br>LO-MOUNT FOR WINCH CLEARANCE |
| <b>ACCENT TAPE:</b>  | EAST BLACK   | <b>MUDFLAPS:</b>     | STD   |
| <b>PAINT:</b>  | EAST BLACK<br>SOFT COAT BLACK ON SUSPENSION                            | <b>TYPE:</b>         | SILVER PLASTIC  |
| <b>WINCH TRACK:</b>  | STANDARD INTEGRATED RAIL   | <b>LOCATION:</b>     | REAR  |
| <b>LOCATION:</b>   |  |                      |   |
| <b>WINCHES:</b>  | 12 - EA. STEEL SLIDING - D/S   |                      |   |
| <b>WINCH CLIPS:</b>  | 12 - EA. SLIDING CLIPS - P/S   |                      |   |
| <b>STRAPS:</b>   | NONE   |                      |   |

**REMARK** REF 76820

- EXTRA ISO 7 WAY PLUG WIRED TO JUNCTION BOX D/S INSIDE FRAME IN FRONT OF MOST FORWARD AXLE.
- TRUCKLITE REGISTRATION HOLDER D/S @ LANDING GEAR
- WIRING BACK 3" FROM INSIDE NOSE - SEE PICTURE

**WEIGHT: +/-3%: 9421**

**DISCLAIMER**

Specifications are believed to be correct, but may contain errors and/or omissions. Photographs are the representative of the subject equipment but may not be identical. Equipment availability, prices and specifications are subject to change without notice.

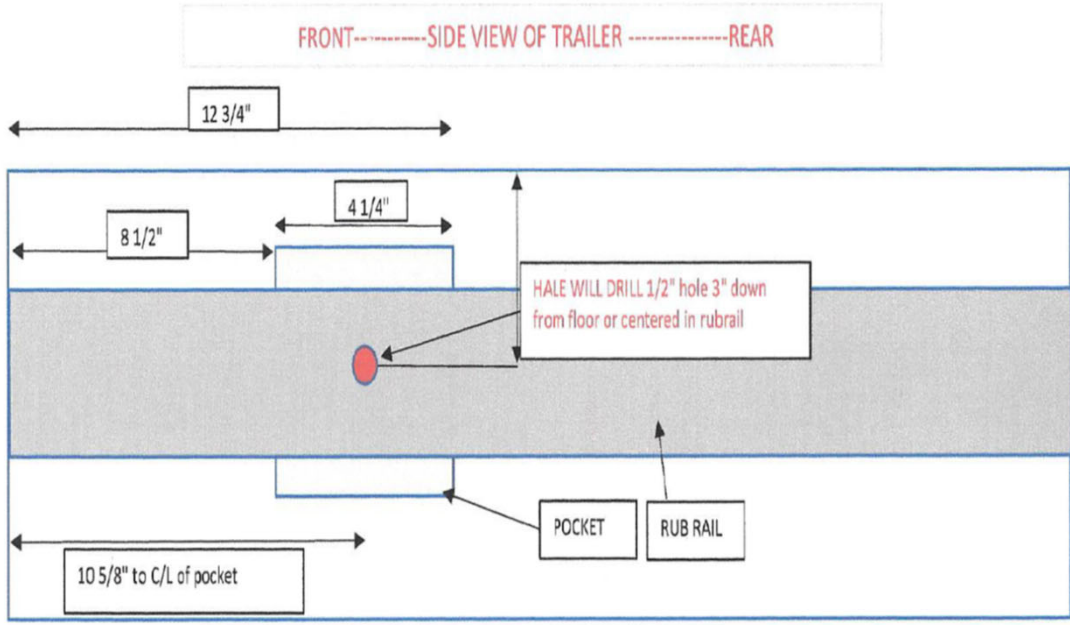

ELECTRICAL HARNESS TO BE BELOW OR ABOVE 1/2" HOLE



WIRING HARNESS TO BE LOCATED 3" REARWARD OF INSIDE 90 DEGREE ANGLE (STANDARD LOCATION OF HARNESS) ALL THE WAY ACROSS THE FRONT OF THE TRAILER

*Hale Trailer*  
*X JBW 4/25/18*  
*X*

|      |                |       |     |
|------|----------------|-------|-----|
| SIZE | DRAWING NO.    | SHEET | REV |
| A    | 0610-4810210-2 | 1     | A   |

- NOTES:
- DO NOT SCALE DRAWING.
  - REMOVE ALL BURRS AND SHARP EDGES.
  - INDUSTRY STANDARDS AND PRACTICES MUST BE APPLIED IN FABRICATION OF PARTS.
  - PART TO BE FREE FROM SURFACE IMPERFECTIONS OTHER THAN SURFACE FINISH REQUIREMENTS.
  - CRITICAL DIMENSIONS ARE INDICATED BY ●
  - THIS DRAWING WAS ORIGINATED BY AND IS THE EXCLUSIVE PROPERTY OF AERO INDUSTRIES, INC. AND/OR ITS OWNER. IT IS NOT AN AUTHORIZATION OR LICENSE TO MAKE THIS CONSTRUCTION OR TO FURNISH THIS INFORMATION TO OTHER PARTIES.

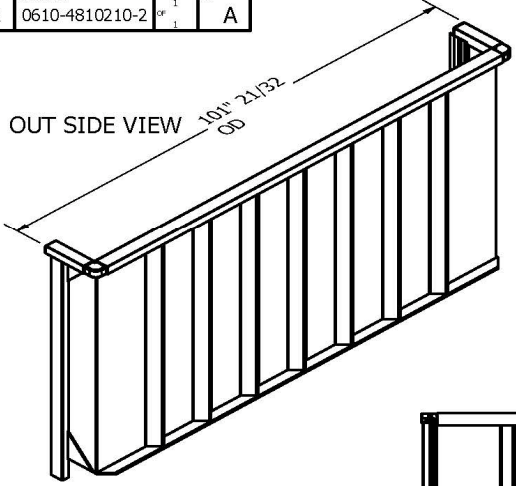

INSIDE VIEW

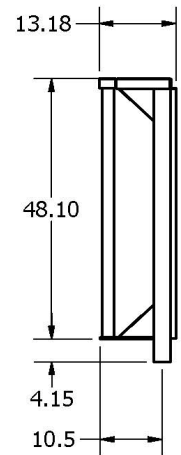
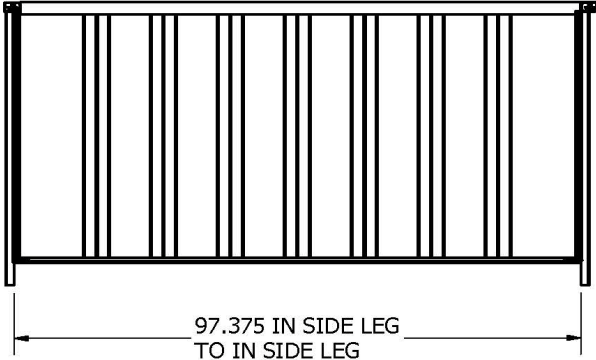

|      |                       |                            |     |
|------|-----------------------|----------------------------|-----|
| 7    | 0611-960125           | LEG ASSY BULKHEAD ALUM P/S | 1   |
| 6    | 0611-960126           | LEG ASSY BULKHEAD ALUM D/S | 1   |
| 5    | 0611-860132           | GUSSET BULKHEAD DOT        | 4   |
| 4    | TOP RAIL ASSY 102W    |                            | 1   |
| 3    | BOTTOM RAIL ASSY 102W |                            | 1   |
| 2    | 860159                |                            | 1   |
| ITEM | PART NUMBER           | DESCRIPTION                | QTY |

| REV              | DESCRIPTION | BY | DATE |
|------------------|-------------|----|------|
| <b>REVISIONS</b> |             |    |      |

|                                       |                 |               |
|---------------------------------------|-----------------|---------------|
| TOLERANCES UNLESS OTHERWISE SPECIFIED |                 | MATERIAL NOTE |
| DIMENSIONS IN INCHES                  |                 |               |
| .X/ = ± .1716                         |                 |               |
| .X = ± .051                           |                 |               |
| .XX = ± .020                          |                 |               |
| .XXX = ± .010                         |                 |               |
| .XXXX = ± .005                        |                 |               |
| ANGLE = ± 1.0°                        |                 |               |
| SURFACE = 125                         |                 |               |
| USED ON                               | MATERIAL FINISH |               |

P:\INVENTOR 2012\0610\0610-4810210-2.idw

TITLE: BULKHEAD ALUM 48"x102" 10" WRAP

|            |                            |              |                 |
|------------|----------------------------|--------------|-----------------|
| SCALE: 1:1 | DRAWN BY: MJB              | APPROVED BY: | DATE: 8/28/2017 |
| SIZE: A    | DRAWING NO: 0610-4810210-2 | SHEET: 1     | REV: A          |

2

1