



Hale Trailer Brake & Wheel
A008491-A008500
VIN: P2487,P2488,P2490,P2550,P2551,P2553
P2555,P2556,P2562,P2563



Detailed Specifications

MAG FA5160 54 (Model: AXM516054RS)

General	
SKU	AXM516054RS
Length	54 inches
Width	8 feet 6 inches
Compatibility	MAG 51, MAG 55H, MAG 55M, MAG 55MX, MAG 55L P, MAG 60
Accent Package	None
Weight	Est. Configured Weight: 2740# +/- 3%
Rear Bridge: General	
Boom Trough	V Crossmembers with Bolt-In V Pan
Rear Bridge: Axles	
Number of Axles	1
Axle Capacity	25,000 lb. Nominal Capacity Per Axle NOTE: GAWR Determined by Suspension Type, Brakes, Tires and Other Components.
Axle Spread	54.5 inches (Between Axles)
Brakes	16.5 inches x 7 inches with 5.5 inches Autoslacks - Heavy Duty Brake Drums - Outboard Mount
Dust Shield	None
Hubodometer	None
Rear Bridge: Suspension	
Manual Dump Valve	Manual Dump Valve
Load Scale	None
Wheels and Tires	
Wheels	8.25 x 22.5 LvL One Buffed Outside/Steel Inside - Hub-Piloted
Tires	275/70R 22.5 H Ply OEM Standard
Inflation	None
Lighting	
Electrical System	DOT Sealed Beam and Harness with LED Lights and 4-inch Flush Mounted Battery Powered Amber Strobes
Tail Lights	3 Tail Light Package
Bumper	Heavy Duty V-Style Rear Bumper
Paint	
Paint	Fontaine Black Polyurethane Enamel
Miscellaneous	
Lash Rings	1 Pair - 2 Total
Flag Holders	1 Pair Flag Holders
Terms	
Please Note	Price Includes Commodity Surcharges
Commercial Terms	Ex Works- Springville, AL, USA

DISCLAIMER

Specifications are believed to be correct, but may contain errors and/or omissions. Photographs are the representative of the subject equipment but may not be identical. Equipment availability, prices and specifications are subject to change without notice.

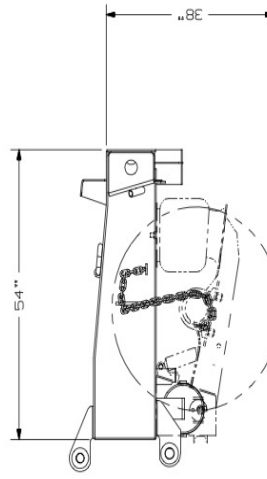
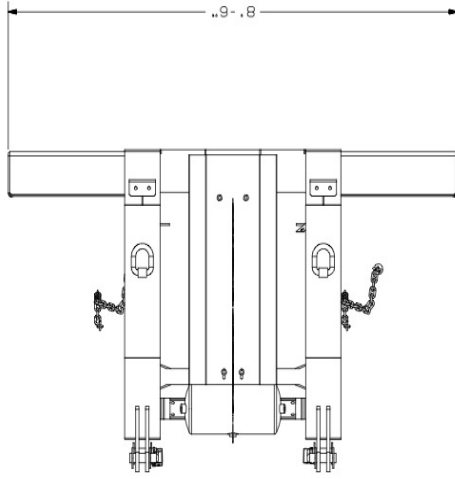

FONTAINE HEAVY-HAUL
SPRINGVILLE, AL
MODEL MAG FA5160 54
DRAWING NUMBER 6462

THIS DRAWING IS THE PROPERTY OF FONTAINE HEAVY-HAUL, INC. IT IS TO BE USED ONLY FOR THE PURPOSES SPECIFIED HEREON. IT IS NOT TO BE REPRODUCED, COPIED, OR TRANSMITTED IN ANY FORM OR BY ANY MEANS, ELECTRONIC OR MECHANICAL, INCLUDING PHOTOCOPYING, RECORDING, OR BY ANY INFORMATION STORAGE AND RETRIEVAL SYSTEM. ANY UNAUTHORIZED USE OF THIS DRAWING IS PROHIBITED AND WILL BE CONSIDERED A VIOLATION OF FEDERAL TRADEMARK AND COPYRIGHT LAWS. FONTAINE HEAVY-HAUL, INC. SPRINGVILLE, AL 35894