

HALE

TRAILER

BRAKE & WHEEL



A019363-A019366
VIN: 86597-86600

SALES | RENTALS | PARTS | SERVICE

Allentown, PA: 800-383-8894 Jacksonville, FL: 800-828-3055
 Baltimore, MD: 888-601-7500 Little Rock, AR: 833-424-8944
 Boston, MA: 800-854-5310 Portland, ME: 800-325-4253
 Concord, NC: 800-438-2250 Richmond, VA: 866-839-3495
 Delmar, DE: 866-486-1400 Scranton, PA: 800-569-1400
 Des Moines, IA: 888-673-5011 Springfield, MA: 800-854-5306
 Elkton, MD: 800-544-7127 Voorhees, NJ: 866-315-0235

HaleTrailer.com | @haletrailer
800-232-6535 *FINANCING AVAILABLE

ALUMINUM "BST II" PLATFORM TRAILER

LENGTH:	48' - 24" BEAM	SUSPENSION:	AAT25K/E2-1 REAR AXLE SLIDER (2)
WIDTH:	102"	LOWERING KIT:	AUTOMATIC
NOSE:	SQUARE + EXTRA 6 WAY CONNECTOR (1)(4)	AXLE TO AXLE:	56" & 125" (2)
KING PIN SETTING:	30" - 5/16" PLATE - NO ACCESS HOLES	AXLE TO REAR:	46"
FLOOR:	KNURLED ALUMINUM 3 NAILERS INTEGRATED SIDE RAIL	LIFT / AXLE:	N/A
XMEMBER SPACING:	16" SPACING	SPACING:	N/A
COIL PACKAGE:	YES (CENTER)-W/ 8 PCS BAR INSERT	F.W. HEIGHT:	49"
SPOOLS:	DOUBLE	CONTROLS:	N/A
POCKETS:	HD FRONT TO ACCEPT AERO BH - SEE DWG	AXLES:	TP 23,000 GAWR
ROPE HOOKS:	NONE	AUTO SLACKS:	MERITOR
TIE DOWNS:	TWO TIE DOWN STORAGE PIPES D/S @ LG	BRAKES:	16 1/2" X 7"
MARKER LIGHTS:	LED - 7 PR EA. SIDE	ABS SYSTEM:	4S/2M
MID TURN SIGNAL:	MMTS BELOW RAIL - INBOARD	HUBS:	10 STUD LW STEEL LWBD
FLAT <input checked="" type="radio"/> ANGLED <input type="radio"/>		WHEELS:	8.25 X 22.5 8 HP / 4 MP
LIGHT PANEL:	LED - 9 LIGHTS (OOO ooo OOO) 1/2 STEPS ON REAR FULL WIDTH BUMPER	TIRES:	11R 22.5 R196A BRIDGESTONE
BULKHEAD:	NONE	LANDING GEAR:	JOST AX150 ALUMILIGHT D/S CRANK FORWARD BRACING (3)
TYPE:		TIRE CARRIER:	BRACKETS ONLY - P/S ACCESS MID TRAILER
HEIGHT:		TOOLBOX: QTY:	NONE
RETURNS:		SIZE:	
MAT'L:		LOCATION:	
ACCENT TAPE:	BLACK	MAT'L:	
PAINT:	BLACK SOFTCOAT BLACK ON SUSPENSION	MUDFLAPS:	STD
WINCH TRACK:	STANDARD INTEGRATED RAIL	TYPE:	SILVER PLASTIC
LOCATION:		LOCATION:	ON REAR OF SLIDER BOX + 3/16" ALUMINUM ON TOP OF SLIDER FLAP BENT TOWARD TIRE
WINCHES:	12 - EA. EXTREME ZINC - D/S		
WINCH CLIPS:	12 - EA. SLIDING CLIPS - P/S		
STRAPS:	NONE		

REMARKS: PRICE SUBJECT TO CHANGE 12 WEEKS PRIOR TO ESTIMATED BUILD DATE

WEIGHT: +/-3%: 9870

- EXTRA 6 WAY WIRED TO JUNCTION BOX D/S INSIDE FRAME IN FRONT OF AXLE #1.
- 2 POSITION REAR AXLE SLIDER - SLIDER BOX INSIDE MAIN FRAME RAILS. SLIDER BOX AND REAR HANGERS TO BE BLACK SOFTCOAT - GALVANIZED HANGERS ON FRONT AXLE ONLY.
- TRUCKLITE REGISTRATION HOLDER D/S @ LANDING GEAR
- WIRING BACK 3" FROM INSIDE NOSE

DISCLAIMER

Specifications are believed to be correct, but may contain errors and/or omissions. Photographs are the representative of the subject equipment but may not be identical. Equipment availability, prices and specifications are subject to change without notice.

FRONT-----SIDE VIEW OF TRAILER -----REAR

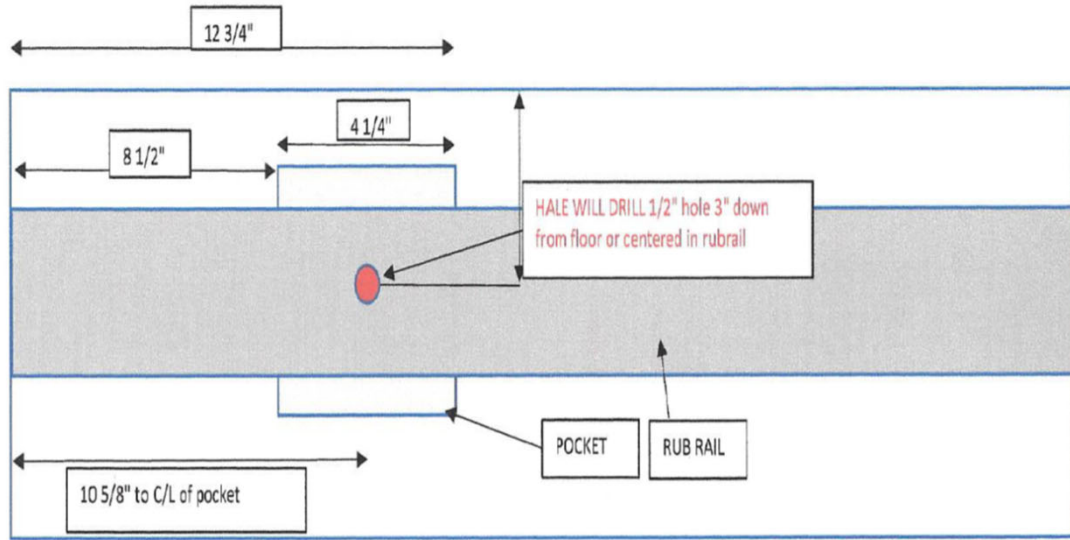

ELECTRICAL HARNESS TO BE BELOW OR ABOVE 1/2" HOLE

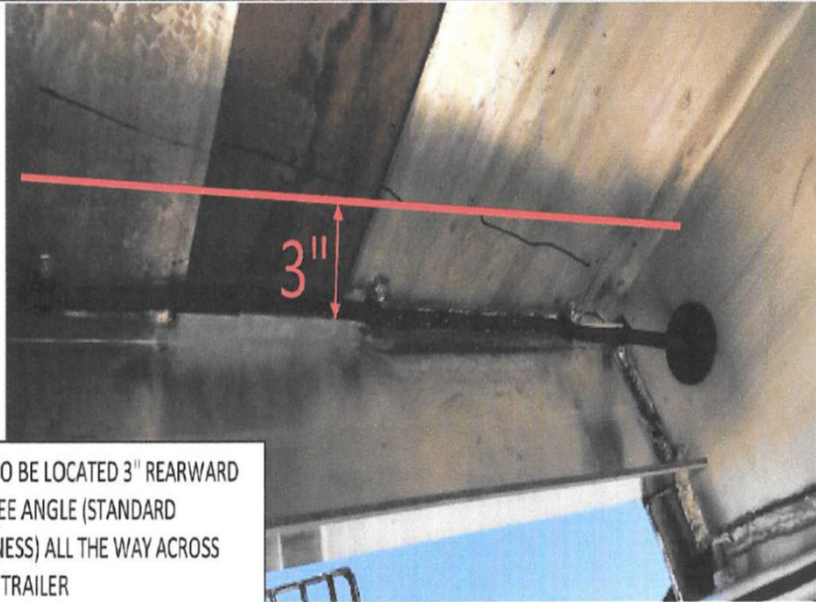

WIRING HARNESS TO BE LOCATED 3" REARWARD OF INSIDE 90 DEGREE ANGLE (STANDARD LOCATION OF HARNESS) ALL THE WAY ACROSS THE FRONT OF THE TRAILER

Hale Trailer
X JB 4/25/18

X _____

NOTES:
 1. DO NOT SCALE DRAWING.
 2. REMOVE ALL BURRS AND SHARP EDGES.
 3. INDUSTRY STANDARDS AND PRACTICES MUST BE APPLIED IN FABRICATION OF PARTS.
 4. PART TO BE FREE FROM SURFACE IMPERFECTIONS OTHER THAN SURFACE FINISH REQUIREMENTS.
 5. CRITICAL DIMENSIONS ARE INDICATED BY ●
 6. THIS DRAWING WAS ORIGINATED BY AND IS THE EXCLUSIVE PROPERTY OF AERO INDUSTRIES, INC. AND/OR ITS OWNER. IT IS NOT AN AUTHORIZATION OR LICENSE TO MAKE THIS CONSTRUCTION OR TO FURNISH THIS INFORMATION TO OTHER PARTIES.

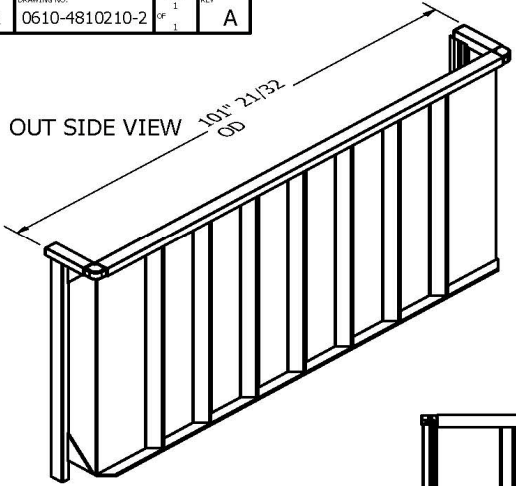

INSIDE VIEW

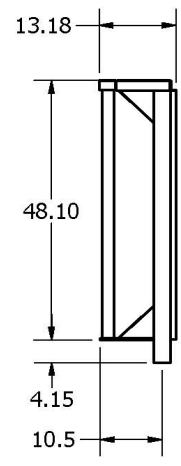
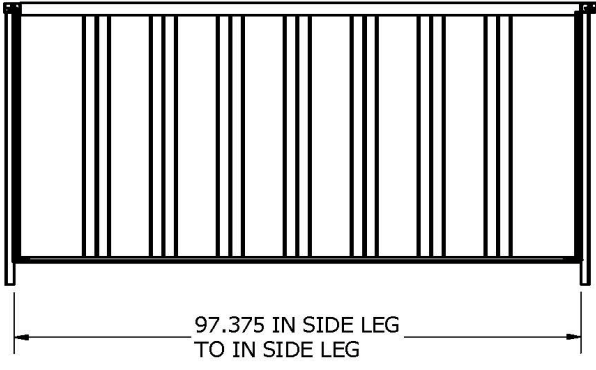

7	0611-960125	LEG ASSY BULKHEAD ALUM P.S	1
6	0611-960126	LEG ASSY BULKHEAD ALUM D.S	1
5	0611-860132	GUSSET BULKHEAD DOT	4
4	TOP RAIL ASSY 102W		1
3	BOTTOM RAIL ASSY 102W		1
2	860159		

P:\INVENTOR 2012\0610\0610-4810210-2.idw

TOLERANCES UNLESS OTHERWISE SPECIFIED:		MATERIAL NOTE
DIMENSIONS IN INCHES		
.125 = ± .016		
.125 = ± .031		
.125 = ± .050		
.125 = ± .010		
.125 = ± .005		
ANGLE = ± 12°		
SURFACE = 125/		
USED ON	MATERIAL FINISH	

Aero

TITLE: BULKHEAD ALUM 48"x102" 10" WRAP

SCALE: 1:1
 DRAWN BY: MJB
 APPROVED BY: [Signature]
 DATE: 7/29/2012

SIZE A	DRAWING NO. 0610-4810210-2	SHEET 1 OF 1	REV A
--------	----------------------------	--------------	-------

REV	DESCRIPTION	BY	DATE
REVISIONS			