

HALE TRAILER BRAKE & WHEEL



A023742-A023756
VIN: 76311-76325

SALES | RENTALS | PARTS | SERVICE

Allentown, PA:	800-383-8894	Little Rock, AR:	833-424-8944
Baltimore, MD:	888-601-7500	Portland, ME:	800-325-4253
Concord, NC:	800-438-2250	Raleigh, NC:	833-418-9777
Delmar, DE:	866-486-1400	Scranton, PA:	800-569-1400
Des Moines, IA:	888-673-5011	Springfield, MA:	800-854-5306
Elkton, MD:	800-544-7127	Voorhees, NJ:	866-315-0235
Jacksonville, FL:	800-828-3055	Walpole, MA:	800-854-5310

haletrailer.com | @haletrailer     

800-232-6535 *FINANCING AVAILABLE

Infinity Drop Deck 53' Rear Axle Slide (Model: HAICD22RSA)

Length / Width: 53 feet x 102 inches

Suspension Type: Rear axle slide

Deck Lengths: 11 feet front and 42 feet rear

Frame Rating: 80,000 lbs distributed - 55,000 lbs concentrated in 4 feet- GAWR and tire ratings determine legal payloads

Rear Deck Height: 40 inches - loaded

Flooring: 1 1/8 inch aluminum with 4 wood nailer strips

Crossmembers: 18 inch centers front deck / 12 inch centers rear deck - 4 inch jr. I-steel

Single Coil Hauling Package: Included

Side Rails: Exclusive **Revolutionary RASR Rail Technology** -- one piece routed aluminum designed for strength and impact

Chain Cargo Tie Downs: 17 pair recessed in siderails

Stake Pockets: Routed aluminum on 24 inch centers (2 load securement openings between stake pockets)

Rubrail: Integrated with siderail

Main Beams: 130K load bearing flanges

Kingpin: 30 inches

Loaded Fifth Wheel Height: 49 inches

Landing Gear: OEM standard

Knee Braces: Fabricated on approx. 60 inch C/C

Bulkhead Pockets: 4 DOT type bulkhead pockets only - welded to front

Bulkheads: None standard

Number of Axles: 2

Axle Spindle: Tapered

Brakes: Spring brakes, auto slacks

Air Line Filters: (2) Meritor In-line installed

ABS: 2S/1M Basic System Requested by Customer - no cable or tool

Axle Spread: 122 inches open - 61 inches closed: Meets California, Canadian RTAC and BC dimensional specifications in closed position

Hub and Drums: 10-hole hub-piloted with outboard cast drums

Wheel Ends: Grease in hubs - *** 5-year wheel end warranty ***

Wheels: 22.5 x 8.25 steel disc wheels - pre-painted white - STANDARD

Tires: 255/70R 22.5 16PR GENERAL HT+

Tire Inflation System: None standard

Suspension Detail: Hendrickson AANL23K and AAZL23K buttoned-up Intraax air ride axles

Air Assist Slide Box Pins: Standard mount of controls on slider frame

Auto Glad Hand Dump: Installed

Electric Dump Valve: Wired to 7-way auxiliary socket to dump rear axle

Front Corners: Tapered

Electrical System: LED: 3 lights/side, 2 lights/side on rear - STANDARD

Paint: Black urethane on steel parts with Infinity decals - STANDARD

Conspicuity Tape: Per NHTSA specs - installed in recess on rubrails

Bumper: Weld-on type - meets underride requirements - painted steel

Mudflaps: 1 set OEM standard behind rear axle only

Winch Track: Full length integrated double L type aluminum on both sides where possible -- STANDARD

Sliding Winches: 12 total, 2 front deck and 10 rear deck: 6 each side; sliding Rope Hook/ Winch Strap Hook Retainers -- STANDARD

27 foot Winch Straps: None standard

30 foot Winch Straps: None standard

Dock Bumpers: 1 pair rubber on rear

Spare Tire Carrier: 1 standard - mounted between lower gooseneck beams at drop

Hubodometer: None standard

Registration Holder: Install registration holder - OEM standard

Tool Box: None standard

VIN Plate: Bilingual US/Canadian VIN plate

Unit Numbers & Decals: Not installed

Stacking: Price includes Standard stacking of each trailer

DISCLAIMER

Specifications are believed to be correct, but may contain errors and/or omissions. Photographs are the representative of the subject equipment but may not be identical.

Equipment availability, prices and specifications are subject to change without notice.

THIS DOCUMENT REMAINS PROPERTY OF FONTAINE TRAILER COMPANY. ITS CONTENTS ARE CONFIDENTIAL AND PROPRIETARY. DO NOT REPRODUCE, USE OR DISCLOSE ANY INFORMATION WITHOUT WRITTEN CONSENT FROM FONTAINE TRAILER COMPANY.

NOTE:
 FRAME RATINGS DENOTE WHAT THE TRAILER FRAME IS CAPABLE OF SUPPORTING. THE SUSPENSION/TIRES MAY NOT BE CAPABLE OF SUPPORTING THESE LOADS WHEN CONCENTRATED OVER THE SUSPENSION AREA. REFER TO THE TRAILER GVWR AND GAWR.

FRAME RATINGS	
DISTRIBUTED	80,000
COIL	50,160
60"	53,400
120"	57,200
180"	61,600

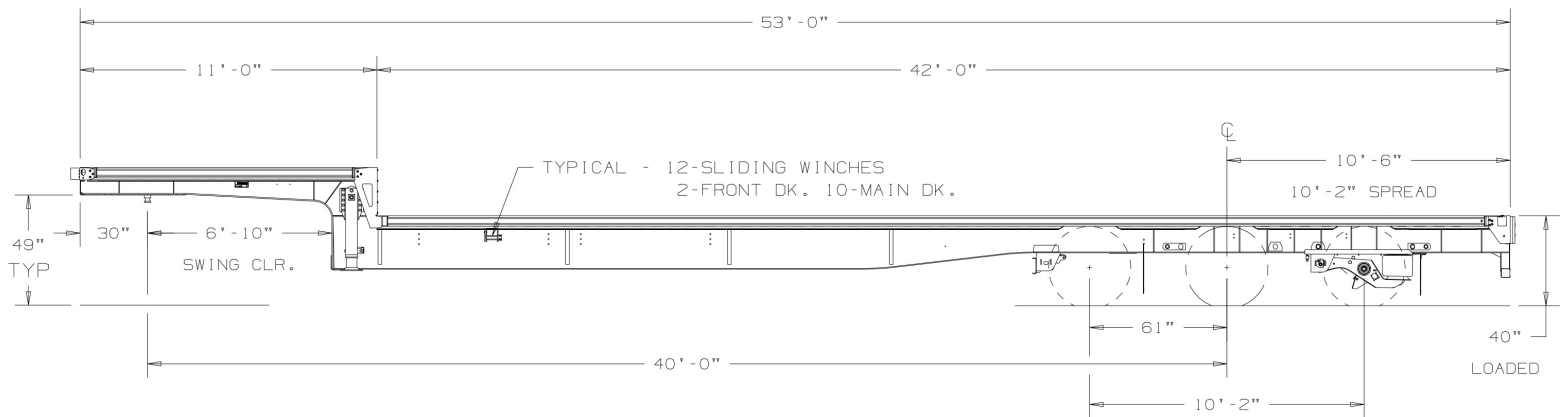
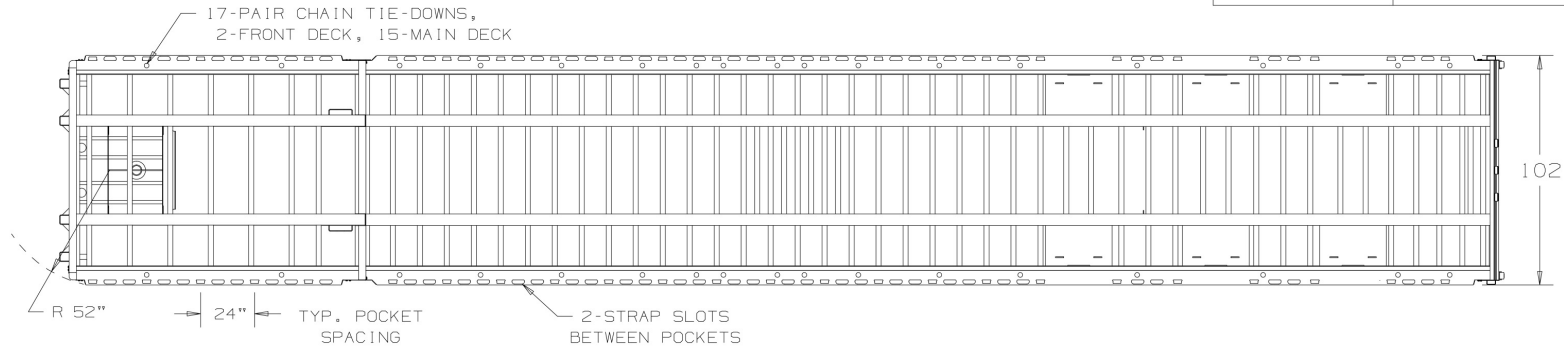

KING PIN HEIGHT RANGE
 47"
 48"
 49" (TYPICAL)
 50"

DO NOT SCALE DRAWING
 DIMENSIONS ADHERE TO:
 ASME Y14.5M-1994

TOLERANCES UNLESS OTHERWISE SPECIFIED
 FRACTIONS: ± 1/8
 DECIMALS: ± .06
 HOLES: ± .005
 ANGLES: ± 2°
 UNITS OF DIMENSION ARE: INCHES

DRAWN BY * DATE *
 CHECKED BY DATE
 APPROVED BY DATE

FONTAINE TRAILER CO.
 HALEYVILLE, AL
 TITLE: HAICD22RSA

PRINTED OR COPIED DOCUMENT IS UNCONTROLLED DOCUMENT UNLESS STAMPED ORIGINAL
 SIZE: A SCALE: *** SHEET: 1 OF 1
 DRAWING NUMBER: 19166 REV. A