

HALE

TRAILER

BRAKE & WHEEL



A024138-A024141
VIN: S023210-S023213

SALES | RENTALS | PARTS | SERVICE

Allentown, PA: 800-383-8894	Little Rock, AR: 833-424-8944
Baltimore, MD: 888-601-7500	Portland, ME: 800-325-4253
Concord, NC: 800-438-2250	Raleigh, NC: 833-418-9777
Delmar, DE: 866-486-1400	Scranton, PA: 800-569-1400
Des Moines, IA: 888-673-5011	Springfield, MA: 800-854-5306
Elkton, MD: 800-544-7127	Voorhees, NJ: 866-315-0235
Jacksonville, FL: 800-828-3055	Walpole, MA: 800-854-5310

haletrailer.com | @haletrailer

800-232-6535 *FINANCING AVAILABLE

Model LRC339 USA 2024

Length 38' / 11.56m	Volume capacity 35 V ³ (yd ³)
Width 102" / 2,59m.	Side loading height 122" / 3,10m
Highest point 133" / 3,38m	Axle spread 54"-54"
King pin set back 16"	Total weight 18000 LB

Bolted Subframe	STRENX, high tensile strength steel 100 000 PSI; Fully hot dip galvanized
Main Beams	STRENX, high tensile strength steel 100 000 PSI;
Tub side walls	HARDOX AR500 TUF 3MM
Cross-members	Bolted I BEAM, help to avoid weld cracks;
Coupling plate	5/16 STRENX (100,000 PSI), with convex shape at king pin;
Tailgate	Aluminum made, using 2 pneumatic cylinders
Safety lock	pneumatic cylinders
Outside walls	Aluminum 14 gauge (0.064") unpolished,
Paint Sandblast	cleaned + epoxy primer, + polyurethane paint, black or customer color;
Self-Steer Axle	N/A
Primary axles	INTRAAX HENDRICKSON ZMD F24, capacity 25 000 Lbs.
Suspension SSA	N/A
Suspension primary	INTRAAX HENDRICKSON, capacity of 25,000 lbs;
Hub&drums	WEBB, unimount 10 holes, long stud;
Brake friction mat	16.5 X 7 Q-brake;
Brake cylinder	booster Type 30/30, 2.5" of stroke;
Slack adjustor	MERITOR, 5.5";
Bearings	Inner bearing and outer bearing # 518445;
Wheels seals	STEMCO GUARDIAN;
Nuts for Hub&drums	STEMCO PRO-TORK;
Hubcaps	STEMCO SENTINEL;
Tires	CONTI. HSR2 11R22.5 16 plys CONTI;
Aluminum rims	ALCOA
ABS brake system	MERITOR, 4S/2M;
Lights	GROTE, LED, side signals, on Transport Canada regulations;
Landing gear	HOLLAND MARK "V", two speeds, driver side installation.



Standard equipment included

Axles Fenders	Plastic fenders
Front Fenders	Aluminum, designed to protect frame at tractor drive tires location;
Lifting Fenders	ABS unique design, help to protect mud flaps pinching against tires;
Tailgate (Control)	Opening operation ready to connect to tractor or manually operating;
Tailgate (Indicator)	Open tailgate indicator on both sides;
Tailgate (Speed)	Slowing devices on tailgate opening and safety locks closing operations;
Inspection windows	Both sides on rear, protected by a safety cover;
Ladder on side	Optional
Front door	Included
Probe hole	Located mid-driver Side
Strobes lights	Located on both sides at rear, ready to connect on tractor by customer;
Drop valve	Located in the air box, allow to drop all suspension for long term parking;
Air gauge	Located on driver side at front, show the air pressure in suspension air bags;
Hydraulic gauges	Located on front pressure line , show PSI;
High pressure valve	Optional
Flow control valve	Optional
Check valve	Set on the return line;
Shaft rotation indicator	indicator Both sides at front, shows if conveyor motion is started;
Wet kit hyd	connector's Wing nut type, one male and one female, 1 " diameter;
Lift axle & steer axle	under beam lift connected to an Electric valve wired at the front
Tarp system	See possible options
Conveyor	
Planetary reducer	(2) COMER with (2) 100 cc hydraulic orbital motor;
Normal range	PSI Stall torque is 2 750 PSI decreasing while unloading;
Oil displacement	GPM Tractor must supply from 25 to 35 GPM. (standard dump pump 3 lines);
Conveyor belt	2 ply's belt with cover of 3/16 and 1/16, asphalt resistant;
Conveyor chains	2 chains pintle type, no rollers to seize but must be oiled at all time;
Seals	ABS unique design, bolt on for easy adjustment;
Conv. cross member	Steel tubing 1 X 2 with skates on each end sliding on low friction material;
Chains oiling system	ABS unique design system, located on rear side, using flow control valves.



OPTION

EL CARGO WATERPROOF TARP ELECTRIC

DISK BRAKE INTRAAX HENDRICKSON ON FIX AXLE (MAXX 22T)

HALF-MOON SCRAPER WITH MUD FLAPS

WORKING LIGHT 3X

SHOVEL HOLDER

Hale Package / Back up Alarm / electrical junction box - beside air box

Blow down from cab for tridem

TIRE INFLATING SYSTEM TIRE MAAX PRO

24.5 WHEEL and TIRE

Identical to S4260

DISCLAIMER

Specifications are believed to be correct, but may contain errors and/or omissions. Photographs are the representative of the subject equipment but may not be identical.
Equipment availability, prices and specifications are subject to change without notice.



Conceive, build and sell high quality trailers keeping in constant innovation and giving priority to a close relationship with customers and employees.

Paradesign may vary according to the chosen tarp

Think ahead. Move forward.

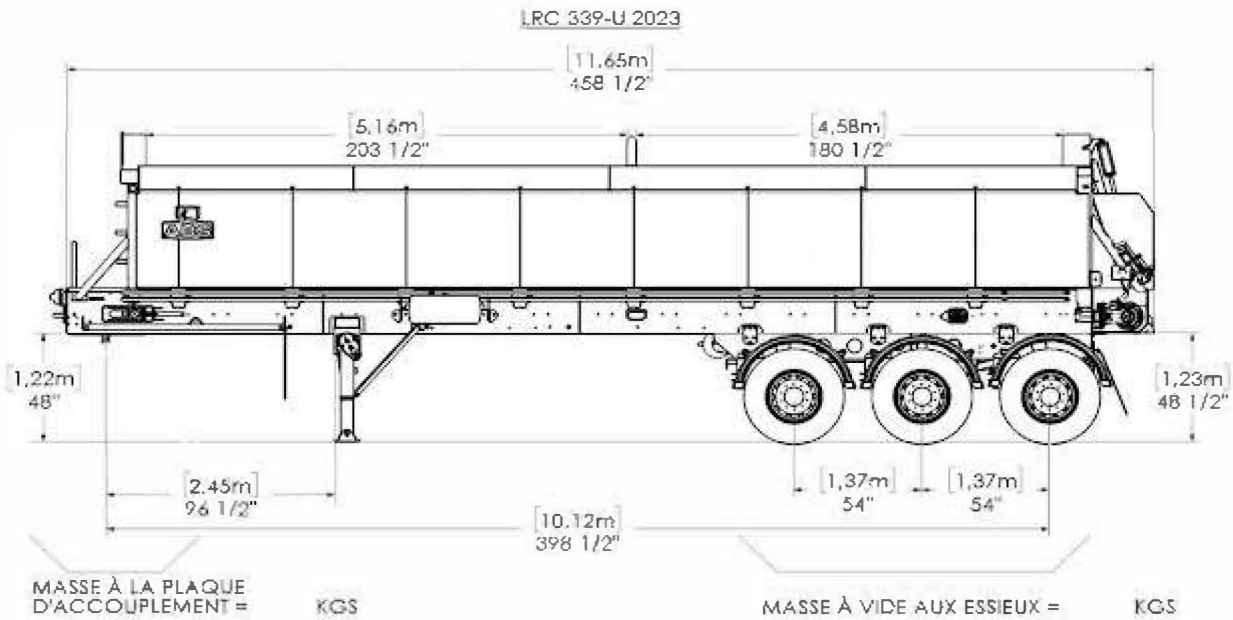

TOTAL MASSE À VIDE = KGS

CAPACITÉ VOLUMIQUE = 35 VERGES/CUBE OU 27 MÈTRES/CUBE

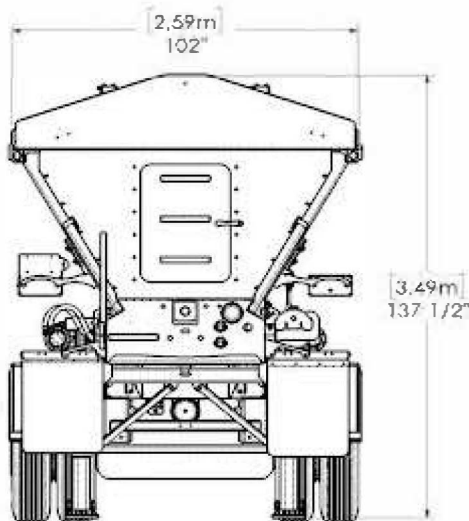

VUE DE DEVANT

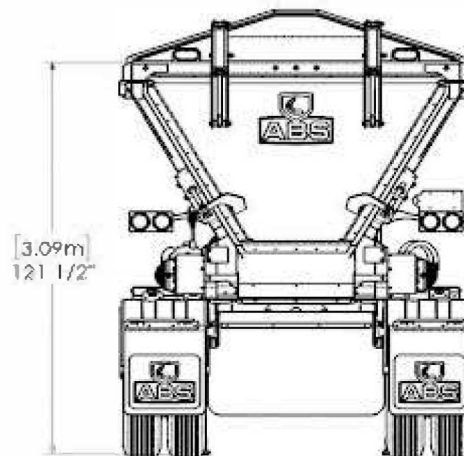

VUE DE DERRIÈRE