

HALE TRAILER BRAKE & WHEEL



037885
VIN: G8423N

SALES | RENTALS | PARTS | SERVICE

Allentown, PA: 800-383-8894	Little Rock, AR: 833-424-8944
Baltimore, MD: 888-601-7500	Portland, ME: 800-325-4253
Concord, NC: 800-438-2250	Raleigh, NC: 833-418-9777
Delmar, DE: 866-486-1400	Scranton, PA: 800-569-1400
Des Moines, IA: 888-673-5011	Springfield, MA: 800-854-5306
Elkton, MD: 800-544-7127	Voorhees, NJ: 866-315-0235
Jacksonville, FL: 800-828-3055	Walpole, MA: 800-854-5310

haletrailer.com | @haletrailer     

800-232-6535 *FINANCING AVAILABLE

Qty	Item	Category	Description	Weight (lbs)
-----	------	----------	-------------	--------------

65265 - TK110J Custom Light Weight 3 axle Jeep

1	65265		65265 TK110J Light Weight Jeep as shown in drawing 65196 with customer supplied tires <i>Ship without Wheels and Tires</i>	9,650
1	08030	Paint	IH Red S7205 with white decals (735-437-010)	
12	67834		67834 Specialized - Deduct for Customer supplied 9 x 22.5 aluminum disc wheels (per Wheel)	
1	67917	Custom Options	Additional load stabilizer brackets on main deck to achieve 36" centers	
1	67918	Custom Options	1 additional pair of removable load stabilizers	
3	9999-01	Custom Options	Dura-lite hubs ILO Alum	

65264 - TK192MDG Custom Light Weight 3 Axle Trailer (13 axle)

1	65264		65264 TK192MDG as shown in drawing 65196 with customer supplied tires. <i>The client has requested a 2" deferential between the top of the load stabilizers and the top of the main rails</i> <i>Ship without wheels and Tires</i>	34,900
---	-------	--	--	--------

1	08030	Paint	IH Red S7205 with white decals (735-437-010)	
1	62362		62362 - TK165MDG - Chain ups on all 3 axles	42
12	67834		67834 Specialized - Deduct for Customer supplied 9 x 22.5 aluminum disc wheels (per Wheel)	
1	67919	Custom Options	Trailer designed for 305/70R22.5 tires on 8.25 x 22.5 aluminum	
1	67920	Custom Options	front GN designed for jeep with 51" fifth-wheel height	
1	65265	Custom Options	Jeep designed to receive future bolt in hydraulic hatbox with 16" vertical lift, 5th wheel height set at 51", Pin on 5th wheel with 30" travel in 5" increments.	
1	67915	Custom Options	Removable inner hydraulic hatbox with 16" vertical lift.	
3	9999-01	Custom Options	dura-lit hubs ILO Alum	

TKMB3 Mechanical booster; 3 axle, 13 axle configuration, 75,000lb cap

STANDARD EQUIPMENT

27,000 lb. axles (3/4" wall)
Chain ups for axle
16 1/2" x 7" air Brakes
Oil seals
Air ride suspension
MF-80 or T-1 equivalent steel construction
14' 1" axle spacing from center of the last axle on the
trailer
to the first axle on the booster
Lifting eye mounted near the front and two D-rings near
the
rear of booster, for point lifting

Remote pivot bearing lube kit
Drop-leg jack
9' overall deck width
Flag holders at rear
Wide Load sign brackets
Rubber mounted sealed LED lights and sealed harness
system
Electrical system per DOT regulations
Mud flaps
Red & white conspicuity markings
Raising/lowering air control panel
Color: Trail King 2-part polyurethane

11860-Base

1	11860	Open Deck	TKMB3 Mechanical booster; 3 axle, 13 axle configuration, 75,000lb cap <i>Goes with TK192MDG G8423</i>
3	11868	Hub / Drum	Duralite hub-piloted - Centrifuse drum ILO Std (per complete axle)
1	9998	Wheel Size	Alternative Option Selected. See Add'l Options Section Below.
1	9998	Wheel Finish (inside)	Alternative Option Selected. See Add'l Options Section Below.
1	9998	Wheel Finish (outside)	Alternative Option Selected. See Add'l Options Section Below.
1	10058	Spare Wheel	No spare wheel
1	9998	Tire Size	Alternative Option Selected. See Add'l Options Section Below.
1	10059	Spare Tires	No spare tire
1	08030	Paint	IH Red S7205 with white decals (735-437-010)

11860-Additional Options

1	64471	64471 General - Deduct Tires and wheels (customer supplied) ILO STD 275's	192
1	64356	64356 TKMB3 9' wide, air ride, 275/70/22.5 on steel wheels, caster self steer axles. This works with 64355. <i>Same as G2424 but with caster steer axles</i>	9,650

DISCLAIMER

Specifications are believed to be correct, but may contain errors and/or omissions. Photographs are the representative of the subject equipment but may not be identical.
Equipment availability, prices and specifications are subject to change without notice.

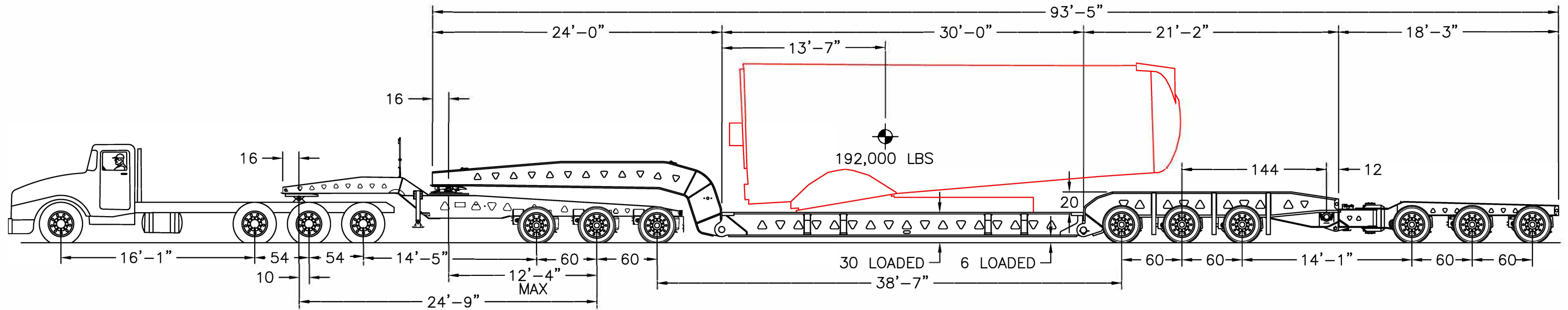
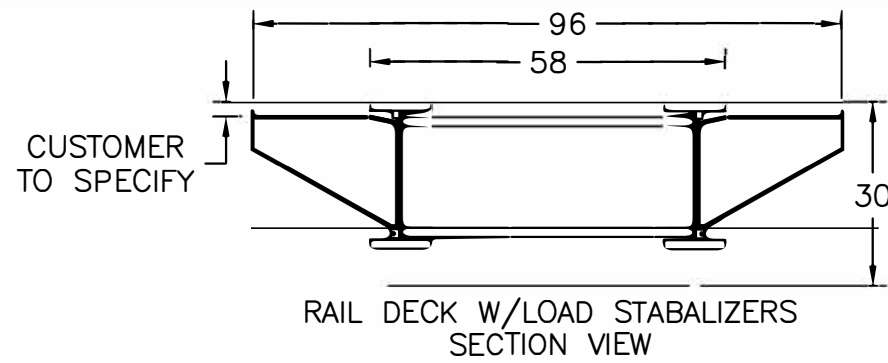

1,948 PAYLOAD
339 TRLR TARE (EST)
10,200 TRUCK TARE
12,487 TOTAL

46,164 PAYLOAD
8,039 TRLR TARE (EST)
8,800 TRUCK TARE
63,002 TOTAL

48,437 PAYLOAD
6,622 TRLR TARE (EST)
7,850 JEEP TARE
62,909 TOTAL

47,891 PAYLOAD
15,600 TRLR TARE (EST)
63,491 TOTAL

47,561 PAYLOAD
15,500 TRLR TARE (EST)
63,061 TOTAL

MODEL TK110J SKELETON STYLE JEEP
CAPACITY 110,000 LBS
WIDTH 8'6"
GOOSENECK... NON DETACHABLE
SUSPENSION.. AIR RIDE W/RAISE & LOWER KIT
TIRE SIZE ... 295/60R X 22.5
WHEELS 9" X 22.5" ALUMINUM DISC (MACHINED FINISH)
OPTIONS 10" SLIDING 5TH WHEEL
ALUMINUM HUBS
CENTRIFUSE DRUMS
PIN TYPE PARK STANDS

ESTIMATED JEEP WEIGHT - 9,650 LBS +/- 3%

MODEL TK192MDG
CAPACITY 192,000 LBS 20 FT
WIDTH 9'0"
GOOSENECK... 24'0" MECHANICAL DETACHABLE
SUSPENSION.. AIR RIDE W/RAISE & LOWER KIT
TIRE SIZE ... 295/60R X 22.5
WHEELS 9" X 22.5" ALUMINUM DISC (MACHINE FINISH)
DECKING N/A
OPTIONS RAIL DECK DESIGN
DETACHABLE WHEEL AREA W/HORIZONTAL PINS
REINFORCED FOR 3 AXLE MECHANICAL BOOSTER
TRIANGLE CUTOUTS ILO D-RINGS
NO BOLSTERS OR AFTERDECK
ALUMINUM HUBS
CENTRIFUSE DRUMS
(4) PAIR LOAD STABILIZERS

ESTIMATED GOOSENECK WEIGHT - 7,900 LBS
ESTIMATED RAIL DECK WEIGHT - 8,900 LBS
ESTIMATED WHEEL AREA WEIGHT - 17,300 LBS
ESTIMATED LOAD STABILIZER WEIGHT - 800 LBS
TOTAL ESTIMATED TRAILER WEIGHT - 34,900 LBS +/- 3%

MODEL TKMB3
WIDTH 9'0"
SUSPENSION.. AIR RIDE W/RAISE & LOWER KIT
TIRE SIZE ... 295/60R X 22.5
WHEELS 9" x 22.5" ALUMINUM DISC (MACHINE FINISH)
OPTIONS DROP LEG JACK
ALUMINUM HUBS
CENTRIFUSE DRUMS
HORIZONTAL PIN CONNECTION (STD)

ESTIMATED BOOSTER WEIGHT - 9,400 LBS +/- 3%

MODEL TK192MDG TRAILER
PROPOSED

TRAIL KING IND. INC.

BOX 1064 - MITCHELL, SD 57301

DRAWN BY DMR	DATE 03/19 2014	IDENT. NO. 65196
-----------------	-----------------------	---------------------

This drawing represents a proprietary product of Trail King Industries, Inc., Mitchell, South Dakota, and shall not be released, disclosed, used, or duplicated, without the written permission of Trail King Industries.