

ART-60-27 Tri-Axle

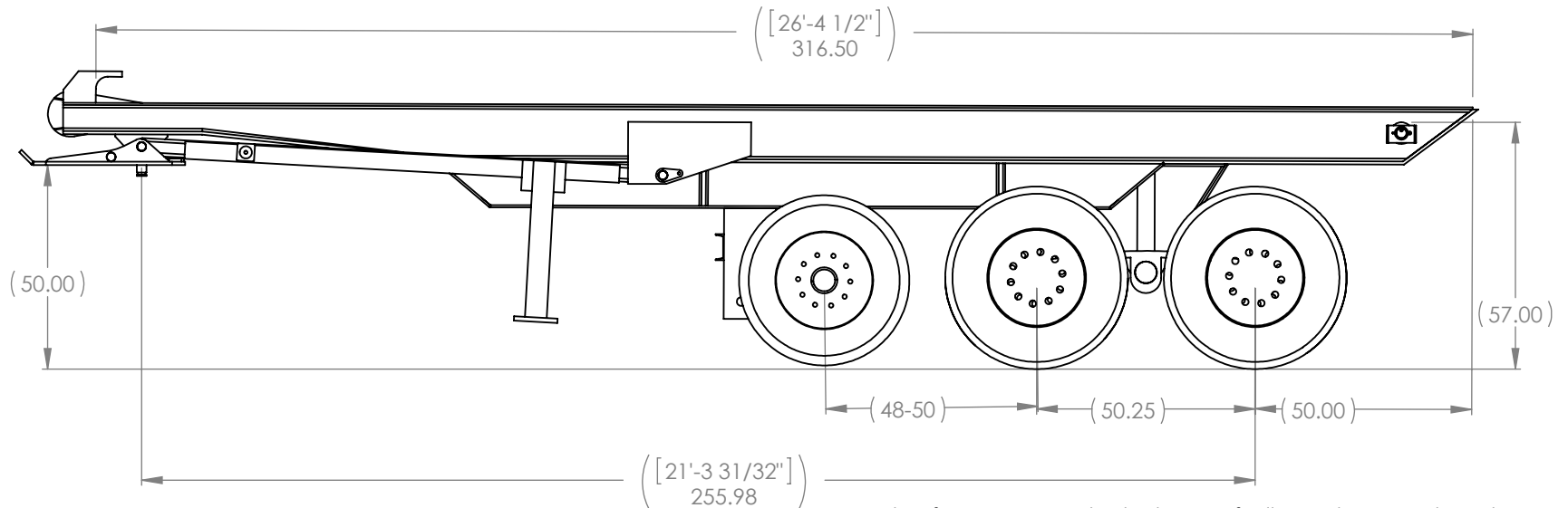

The information contained in this drawing is for illustrated purpose only, Brothers Equipment reserves the right to make changes at any time without notice.

Specification:

60,000# Capacity, Designed to Haul up to 27' Outside Rail Containers
 12"x4"x3/8" Grade A Cross Members, 4"x4"x1/4" Stabilizer Frame
 3/4" King Pin Plate, 3/8"x4" Flat Bar Wear Pad,
 3" Shaft 7" Bore Reeve Cylinder (Duals)
 8"- 4 Stage Telescopic Main Lift Cylinders (Duals)
 7/8" IWRC Cable with 1" Ring
 10" Main Pulley with Bronze Bushing

50,000 # Tandem Single Point Rear Suspension,
 25,000# Axles
 ABS Brakes, D.O.T Lights #108, fixed front stops
 Rear Fenders Rubber on Tandem
 ICC Regulated Bumper- Air Accuated
 Manual outside controls with Air Control Brake
 Color Industrial Enamel with Hardener (Black)

Options:

Air Lift Fourth Axle System
 Aluminum Rims
 Auto Grease System
 Removable Stops

Hydraulic Tarp
 In Cab Controls
 Auto Tire Inflate

HALE

TRAILER

BRAKE & WHEEL

Model: ART-60-27	
Overall Trailer Length:	27
Container Range:	10-50 Cu. Yard
Tare Weight:	14,200
Dump Angle:	43 °F
Container Hold Downs:	Manual Nylon Winch Straps (6)
Hoist Capacity:	60,000 lbs.
Gross Vehicle Weight:	75,000 lbs. Federal
Rollers:	3 1/2" Greasable Box & Stub
Sheeves:	10" with Grease Zerk
Lighting:	LED DOT #108
Axles:	(3) Meritor Rating 25,000 LBS
Suspension:	Hutch H900 50,000 lbs. Single Point Overslung
Lift Suspension	Hendrickson HT250 - Air Lift
Landing Gear:	Jost 180,000 lbs. 2 Speed
Tires:	11R22.5
Wheels:	10 Hole Uni-Mount, Hub Piloted
Fenders:	Rubber
Brake System:	ABS 2S1M
Hydraulics	
Valve Body:	Hydac 4-Spool Directional Valve
Lift Cylinders:	(2) CH 8.5" Dual Double Acting Telescopic
Cable Cylinders:	(2) 7 3/4" DA, 3 1/2" Round, Polished & Chrome
Working Pressure:	2,500 PSI
Hoses:	3,000 psi with Nylon Covering
Frame:	
Tilt Frame:	12"x 4" Rectangular Tubing, 1/2"x 4" Flat Bar
Top Wrap	3/4"x 4" Flat Bar Bottom Wrap
Stabilizer Frame:	4"x 4" Square Tubing, 4"x 4 1/4" Angle Iron
Cable:	7/8" 637 IWRC Wire Rope
Bumper:	ICC FMVSS 223 Certified
Paint:	Cleaned, Primed, Industrial Enamel w/Hardner
Options Installed:	
Tarp System	Roll-Rite Hydraulic Tower/Motor
Automatic Tire Inflation System	Meritor
Steel Tool Box	Mounted Passenger Side

DISCLAIMER

Specifications are believed to be correct, but may contain errors and/or omissions. Photographs are the representative of the subject equipment but may not be identical. Equipment availability, prices and specifications are subject to change without notice.