

# HALE

## TRAILER

### BRAKE & WHEEL



**A022022**  
**VIN: 65619**

#### SALES | RENTALS | PARTS | SERVICE

<b>Allentown, PA:</b>	800-383-8894	<b>Jacksonville, FL:</b>	800-828-3055
<b>Baltimore, MD:</b>	888-601-7500	<b>Little Rock, AR:</b>	833-424-8944
<b>Boston, MA:</b>	800-854-5310	<b>Portland, ME:</b>	800-325-4253
<b>Concord, NC:</b>	800-438-2250	<b>Richmond, VA:</b>	866-839-3495
<b>Delmar, DE:</b>	866-486-1400	<b>Scranton, PA:</b>	800-569-1400
<b>Des Moines, IA:</b>	888-673-5011	<b>Springfield, MA:</b>	800-854-5306
<b>Elkton, MD:</b>	800-544-7127	<b>Voorhees, NJ:</b>	866-315-0235

HaleTrailer.com | @haletrailer     

**800-232-6535** \*FINANCING AVAILABLE

QUANTITY	ONE (1)
BODY TYPE	SWO48102
LENGTH	48'
WIDTH (OVERALL)	102"
SIDES	102" X 1/8" HARDOX, FULL LENGTH
TOP RAIL	6" X 4" X 3/16" TUBE
SIDE POSTS	6" WIDE FORMED CHANNEL ON 24" CENTERS
BOX BRACING	NO
CLEANER PLATES	OUTSIDE (X)                      INSIDE (X)
TARP RODS	NO
TARP SYSTEM	NONE
TARP MATERIAL	NONE
FLOOR	KEITH 2868 FLAT, 5/32", STEEL SLAT 10.5 SC@ 46.9, 3.5" DRIVE 6" STROKE
CROSSMEMBERS	4" JR. I-BEAMS ON 12" CENTERS
CYLINDER	KEITH 3.5" X 10" STROKE
TAILGATE	BARNDOR, HINGED ON CURBSIDE, LADDER SET TO DRIVERSIDE
BULKHEAD	<b>FLAT FRONT X 1/8" HARDOX WITH INSIDE STEPS</b>
LADDER	RUNG STYLE LADDER ON BULKHEAD & REAR DOOR
CATWALK	YES FULL WIDTH WITH LADDER MOUNTED IN MIDDLE (36" WIDE)
LONGITUDINALS	10" X 15#/FT I-BEAM REAR TO LANDING GEAR
AXLES	5" ROUND X 5/8" WALL / 25,000# CAPACITY / 77 1/2" TRACK
BRAKES	16 1/2" X 7" AIR, WITH AUTO SLACK ADJUSTERS
ANTI-LOCK SYSTEM	2S/1M ABS
WHEELS	10 STUD HUBS, OUTBOARD DRUMS (HUB PILOTED, UNI-MOUNT)
RIMS	14" X 22.5" ALUMINUM
TIRES	425/65R-22.5", RADIAL
SUSPENSION	RIDEWELL RAR-266 30K TANDEM
LIFT AXLE(S)	RIDEWELL RAR-266 25K (ONE) - REAR LIFTABLE
KING PIN	36" SETTING ON 3/8" PLATE
LANDING GEAR	HOLLAND MARK V, TWO SPEED, HEAVY DUTY
TIRE CARRIER	NO
LIGHTS	TRUCK-LITE LED SEALED SYSTEM W/ BACKUP LIGHTS
MUD FLAPS	RUBBER REAR
BUMPER	ICC / PUSHER BUMPER W/ TOW HOOKS (2)
HYDRAULIC FITTINGS	5100-S5-16B (PRESSURE) / 5100-S2-20B (RETURN)
HYDRAULIC HOSES	1" X 168" (3000 PSI)
SPREADER BAR	CENTER (X)                      REAR (X)
PAINT	ONE COLOR
<b>OPTIONS</b>	DUMP VALVE TO DUMP ALL AIR AT ONCE
	7 WAY AUX TO LIFT AXLE
	AIR GAGE MOUNTED TO DRIVER SIDE NOSE
	TIRE INFLATION SYSTEM
	MAN DOOR LOCATED IN BULKHEAD UNDER CATWALK

#### DISCLAIMER

Specifications are believed to be correct, but may contain errors and/or omissions. Photographs are the representative of the subject equipment but may not be identical. Equipment availability, prices and specifications are subject to change without notice.

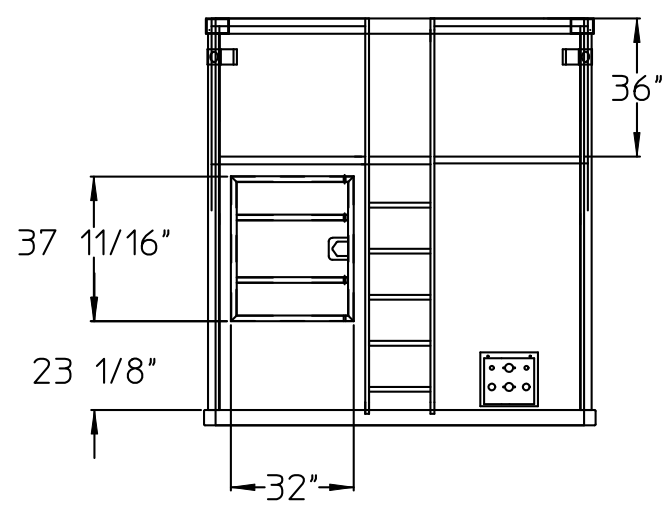
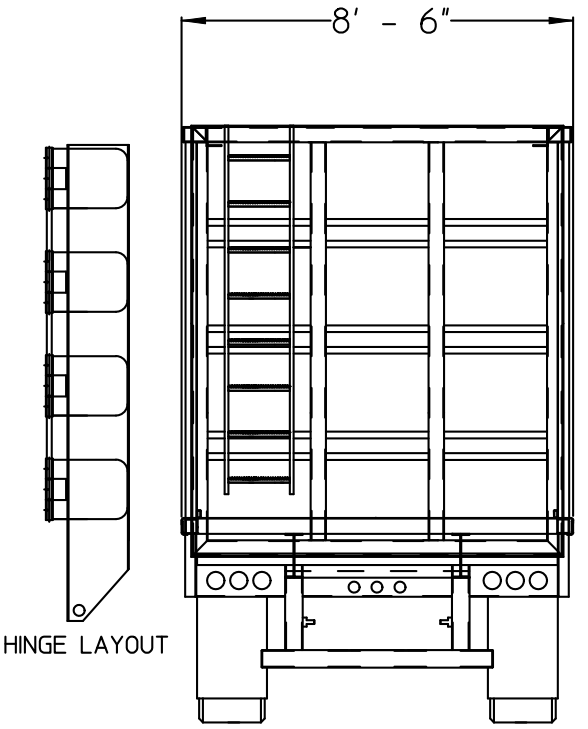
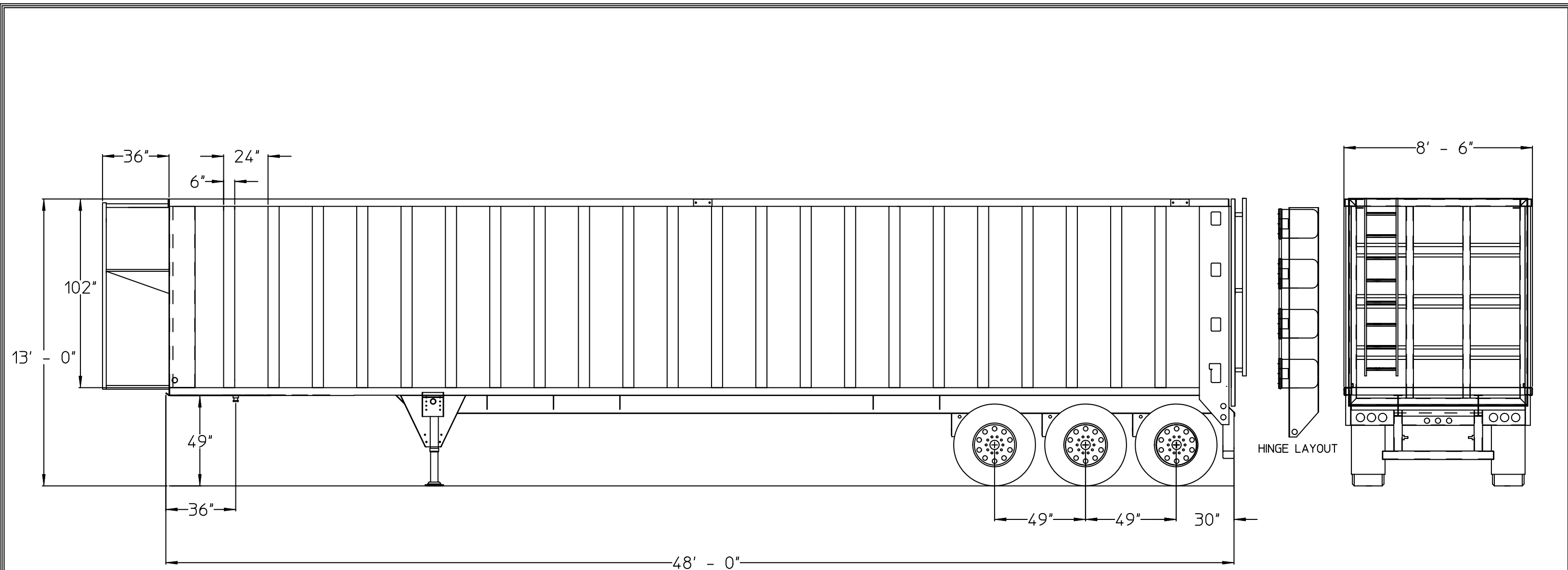

DRAWN BY TAYLOR		P.O. BOX 760 PARRAGOULD, AR 72450 PHONE: (870) 236-7753	
SCALE NTS			
DATE 1-26-24			
TITLE 48' X 13'-0" X 8'-6" STEEL WALKING FLOOR W/SIDE HINGE DOOR TRI-AXLE 30" L.A.		NO INFORMATION CONTAINED IN THIS DOCUMENT MAY BE USED IN ANY MANNER WITHOUT WRITTEN AUTHORIZATION FROM PEERLESS CORPORATION.	
		DRAWING No. SWO-48-102	ISSUE 1